

# SMOKE & OIL

The Official Mardi Gras MGs of Fairhope, Alabama  
A chapter of the North American MGB Register.  
An affiliated chapter of *THE MG OWNERS CLUB (U.K.)*



## YOUR CHAIRMAN SPEAKS...

Greetings from your Atmore Connection.

By the time you read this, we will have said our goodbyes to Moody Steadham, who died last week. Moody was always one of our most dedicated MGMG members, and we will miss him. But what a pleasure it was to be able to get to know him and spend time with him. Whether it was a tech session, club meeting or event, he was always there. You could count on Moody. And who will ever forget those oyster roasts, and his birthday party (this past summer).

Moody was an unique individual in many ways, but what tops my list is the fact that one of his ancestors came over on the KALMAR NYCKEL, a sailing ship, which landed in what is now Delaware about 1638. So it seems that Moody's family and my mother's family were among the early Delaware settlers. Moody's ancestors also include Native Americans, and he was a member of the Poarch Band of Creek Indians.

Moody was truly a car guy, our car guy, and we will miss him.  
SAFETY FAST, Moody.

Hope to see all of you Wednesday night at our club meeting.

Herb

---

### Club Wheels

CHAIRMAN:

Herb Hackman

EVENTS CHAIRMAN:

Dick Bishop

SECRETARY:

Karen Roloson

NEWSLETTER EDITOR:

Jon Gosnell

MEMBERSHIP CHAIRMAN

Mike Schiebert

## WHO WE ARE

We are a membership organization composed of MG and other British Automobile enthusiasts in the Fairhope and Eastern Shore area who have joined together to preserve and enjoy our motorcars. Since it is the cars that brought us together, our events although are varied, stem around British cars. We have monthly activities of different types including Rallies, Tours, Car Shows, Social Functions, Gymkhanas, Tech Sessions. and lessons on Valet Parking We are affiliated with the North American MGB Register. We welcome anyone who has an interest in British cars. You do not have to own one to become a member. Our meetings are held at the Lake Forest Yacht Club on the first Wednesday of the month at 630 PM .

---

Please send any letters , photographs or items for the newsletter to:

**EDITOR**

[jgosnel2@yahoo.com](mailto:jgosnel2@yahoo.com)

This newsletter is dedicated to Moody



1969 AC Coupe



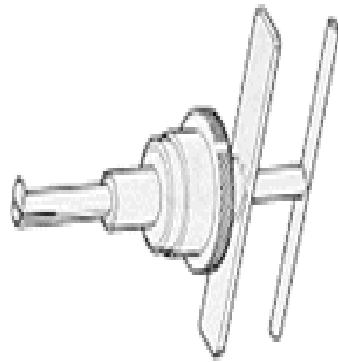

L401A

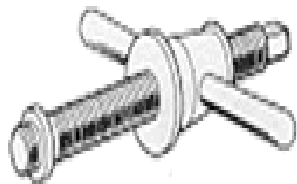

L183A

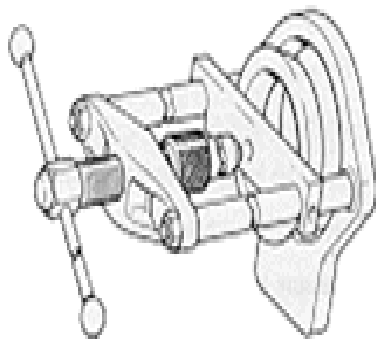

47



**British Leyland Special Service Tools (and their modern equivalents)...**

## SUPPORT OUR LOCAL SPONSORS

**D&D Automotive, 506 Fairhope Av.-(251) 990-5613**

**Fairhope Tires, 19526 Greeno Rd, Fairhope-(251) 928-5613**

**Malone Insurance Agency, 104 Professional Pk. Dr. Fairhope-(251) 990-4000**

**Tony's Towing, Inc. 8326 Nichols Av. Ext. Fairhope-(251) 928-7334 or (251) 626-7339**

**Fairhope Auto Parts (NAPA) 150 N. North Section St. Fairhope (251) 928-2194**

**Penton's Auto Trim & Truck Accessories 4810 North W. St. Pensacola Fl. -\850 432-1825**

**Old Tyme Feed and Seed 19580 Greeno Rd, Fairhope -(251) 929-1156**

**Rogers's Small Engine Repair 111S. Section St. Fairhope-(251) 680-0027**

## TECH TIPS

### DOT 5 Brake Fluid

DOT5 does not absorb water and may be useful where water absorption is a problem.

DOT5 does NOT mix with DOT3 or DOT4. They also maintain that all reported problems with DOT5 are probably due to some degree of mixing with other fluid types.

They said the proper way to convert to DOT5 is to totally rebuild the hydraulic system.

Reports of DOT5 causing premature failure of rubber brake parts were more common with early DOT5 formulations. This is thought to be due to improper addition of swelling agents and has been fixed in recent formulations.

DOT5 is compatible with all rubber formulations.

DOT5 doesn't eat paint.

They also made some general recommendations based on this data and personal experiences. These, along with recommendations of list members included:

If it works for you, use it. You won't hurt anything if you do the conversion correctly.  
(See, #2 above)

Careful bleeding is required to get all of the air out of the system. Small bubbles can form in the fluid that will form large bubbles over time.

It may be necessary to do a series of bleeds.

DOT5 is probably not the thing to use in your race car although it is rated to stand up to the heat generated during racing conditions.

The reason for this recommendation is the difficult bleeding mentioned above.

DOT5 is a good choice for the weekend driver/show car.

It doesn't absorb water and it doesn't eat paint.

One caveat is that because it doesn't absorb water, water that gets in the system will tend to collect at low points. In this scenario, it would actually be promoting corrosion!

Annual flushing might be a good idea.



# **AUTO PARTS**

## **Ray Bozeman -- General Manager**

- Foreign & Domestic
- Rebuilt Starters & Alternators
- Hydraulic Hoses
- Martin Senour Paints
- Small Engine Parts
- Marine Accessories
- Beck Arnley Parts
- Truck • Industrial • Farm

• Your local source for **HARD TO FIND** parts for your British car

**STORE HOURS: M-F 7:30-5:30 Sat 8-2**

**928-2194**



150 NORTH SECTION STREET in FAIRHOPE

# **NAPA AUTO PARTS**

**YOU CAN USE THIS SPACE TO SELL, BUY OR TRADE !**

**YOU CAN PLACE YOUR ADVERTISING HERE!!**

**PLEASE SUPPORT OUR  
SPONSORS**

# NEW SPONSORS



Andy Malone



## FARMERS<sup>®</sup> Malone Insurance Agency

104 Professional Park Drive  
Fairhope, Alabama 36532

**Business: (251) 990-4000**

Fax: (251) 928-0806

Res: (251) 990-7737

andrew@maloneinsurance.com

Auto • Home • Life • Commercial

## OLD TYME FEED & GARDEN SUPPLY, INC.

OLD FASHION VALUES & FRIENDLY SERVICE

*Cecil Christenberry*

OFC: (251) 928-1156

RES: (251) 928-4580

P.O. Box 1377

Fairhope, AL 36533

## Fairhope Tire Ken and Rita Jansen



19526 Greeno Road  
Fairhope, AL 36532  
251-928-5613

Tires  
Brakes  
Alignments

## D&D AUTOMOTIVE

Brakes  
CV Axle



Scanning  
Alignments

**Complete Automotive Repair**

Owner  
**Tracey Daugherty**  
Manager  
Jennifer Hinton

**990-4952**

Mechanics  
**Terry Roberts**  
**Mike Reardon**  
**Brandon Lambert**

## OLD TYME FEED & GARDEN SUPPLY, INC.

OLD FASHION VALUES & FRIENDLY SERVICE

*Cecil Christenberry*

OFC: (251) 928-1156

RES: (251) 928-4580

P.O. Box 1377

Fairhope, AL 36533

## Attention MGMG Members

### Event Schedule for October 2009

#### **3 Oct (Sat) 1400 ... Ice Cream Social hosted by SABCC**

Don't forget the annual SABCC ice cream social scheduled for 2:00 PM, Saturday, October 3 at the

Garagemahal Ice Cream Parlor & Oil Change Emporium in Daphne, Alabama. Once again, Richard & Donna

Cunningham are hosting this very their home (actually their big air located at 25604 Friendship Road. vited.

Photo by Bill Moseley

popular club event at conditioned garage) PBCA and MGMG are in-

To get there, take the highway 98 south toward Daphne. Stay on 98 county road 64 (Daphne Avenue). There is a Target store and a Sonic tion. Turn left on=0 A 64 and go about 3/4 mile and look your right. Turn right on Friendship Road and the first driveway on the left. If you Richard at 402 9919.

exit from I-10 and go until you reach

drive in at the intersec- for Friendship Road on

look for need directions, call

#### **7 Oct (Wed) ... Club Meeting at 1830 club meeting)**

LFYC (1800 socialization,

#### **25 Oct (Sat) ... SABCC British Car Festival car show at Fairhope Beach Park (Shine up your LBC!)**

0900 - 1200 Registration

1200 - 1400 Popular Voting

#### **26 Oct (Sun) Polo at the Point ... MGMG and guests car display (Champagne and Chuk- kers!)**

This is one of our premier events. More info to follow later. A new location for this year.

Moody Millard Steadham, age 78, a native of Wausau, FL and a resident of Fairhope, AL, passed away Wednesday, September 30, 2009. Mr. Steadham was a USAF Training Commander during the Korean War. He was a graduate of Alabama Polytechnic Institute, Auburn, AL, and attended various universities to further his education. Moody worked for Boeing Aircraft, Pilotless aircraft division, NASA Mercury Flights through the Apollo moon landing. He retired from IBM Marketing in 1987. He is survived by his: Wife of 50 years, Betty Steadham of Fairhope; Sons, Gregory M. Steadham of Fairhope, Geoffrey M. Steadham of Gulf Shores; Grandson, Juston Wilson Steadham of Katy, TX; Sisters, Mable Everette and her husband Samuel Smith of Bay Minette, Willie Troutman and her husband Leon of Atmore, Ollie McPhaul of Bay Minette; Nieces, Nephews, other relatives and friends. Memorial services will be held from Jubilee Shores Methodist Church, Monday, October 5, 2009, at 3:00 pm. The family will receive friends after the memorial services. In lieu of flowers, the family suggests that donations be made to Easter Seals, Jubilee Shore United Methodist Church, or American Cancer Society

